

# Lugano

Design by BoConcept

Samvejledning - Assembly Instructions - Montageanleitung - Instructions d'assemblage - Instrucciones de montaje

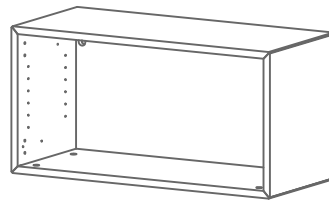

## 2130

38,4x76,8x33,4 cm /  max. 30kg

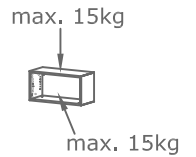

Korpus – Korpus – Carcase – Carcasse  
2130

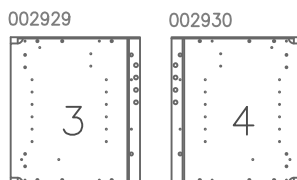
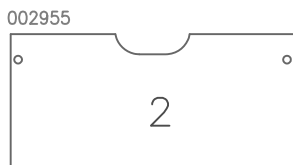
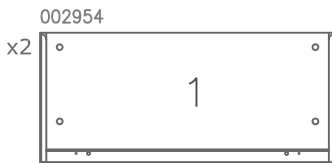

Beslag – Beschläge – Fittings – Set de montage  
2130 – Box no. 930000825

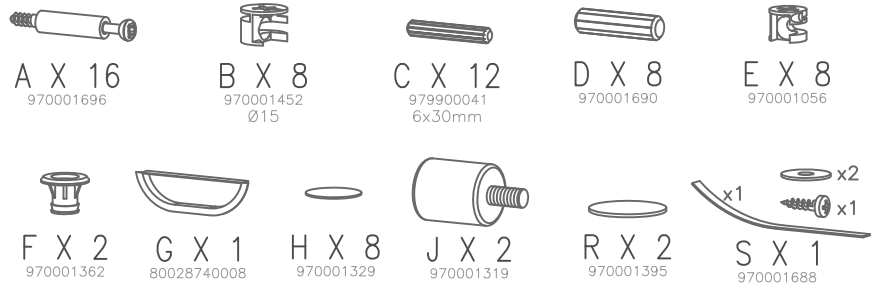

2130 – Box no. 930000819

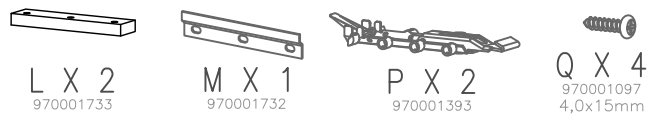

Værktøj – Werkzeuge – Tools – Outils

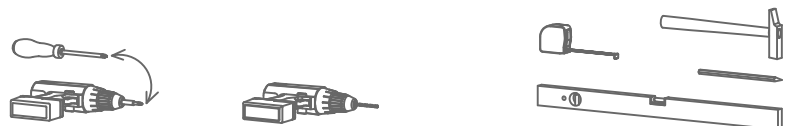

FIG. 1



A X 16



B X 8



C X 12

6x30mm



D X 8



E X 8



F X 2

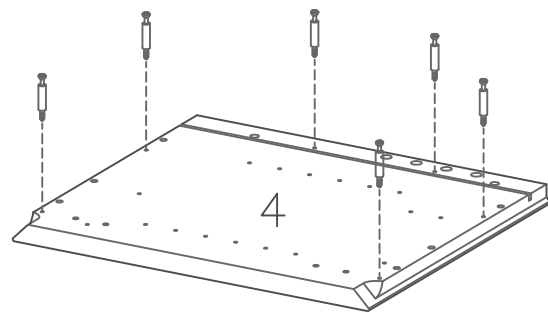
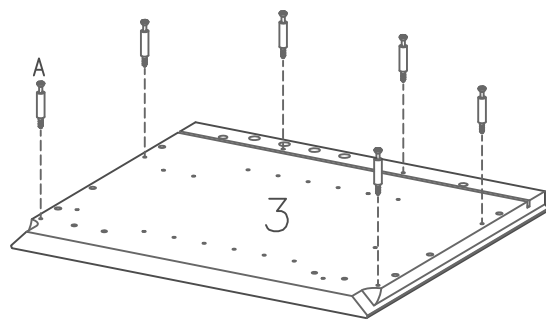
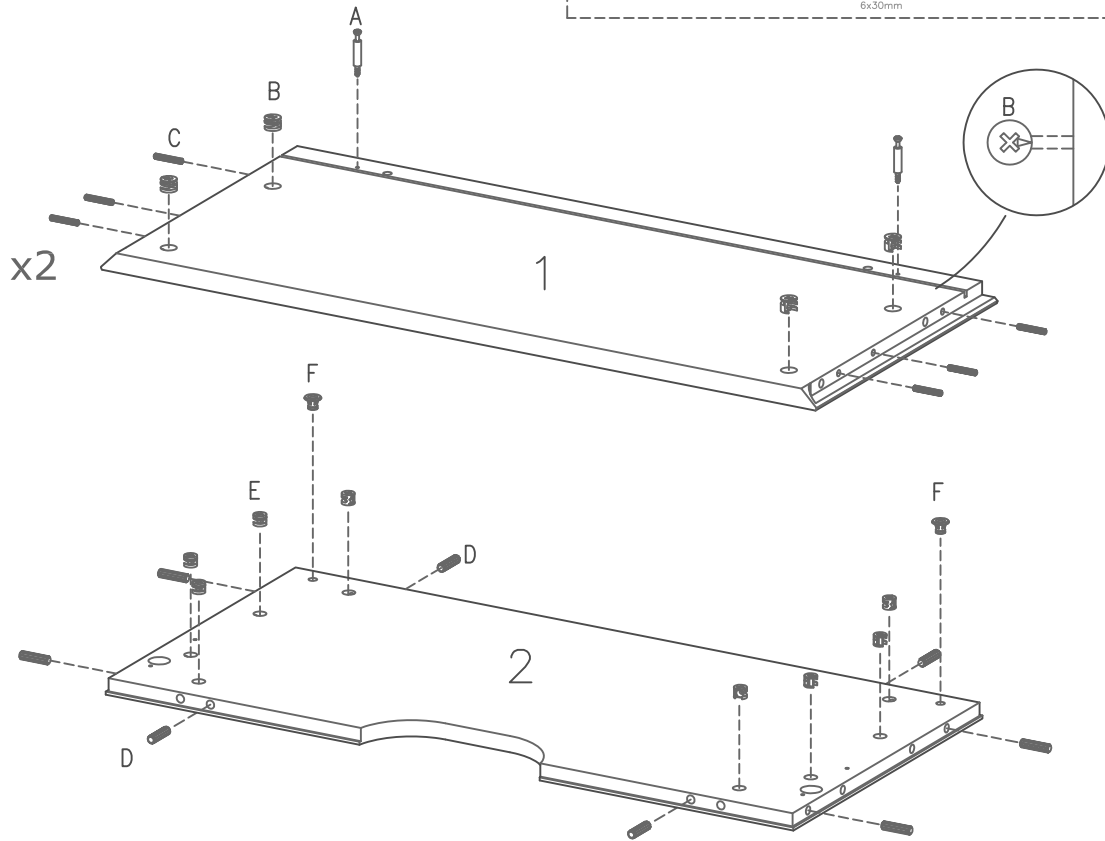

FIG. 2

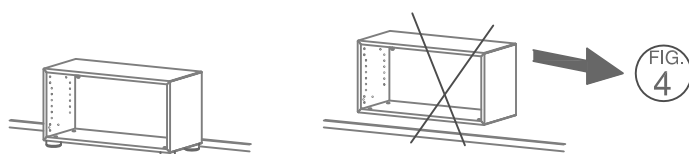

FIG. 4



S X 1



S X 1

Ø16



S X 1

4,0x16mm

Attention!

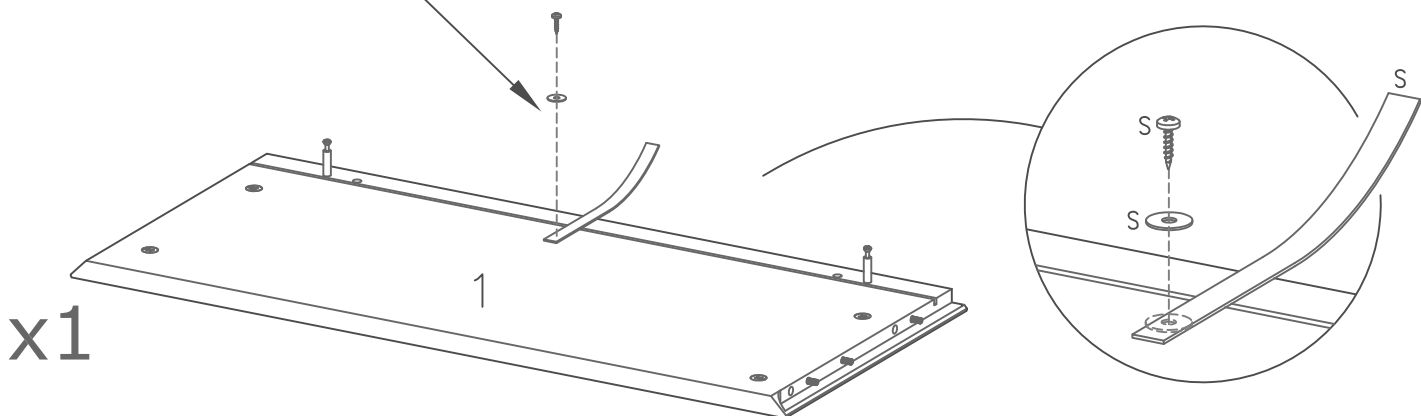
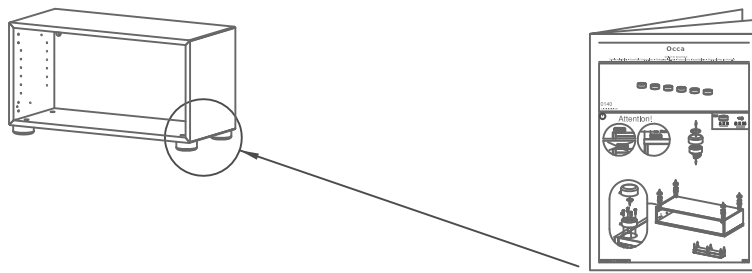

FIG. 3

# Attention!



Samvejledning - Assembly Instructions - Montageanleitung - Instructions d'assemblage - Instrucciones de montaje

FIG. 4

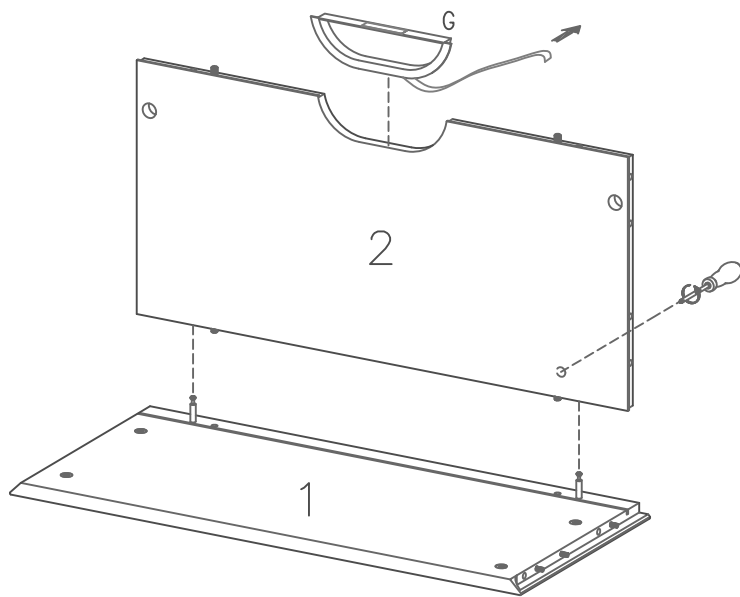

FIG. 5

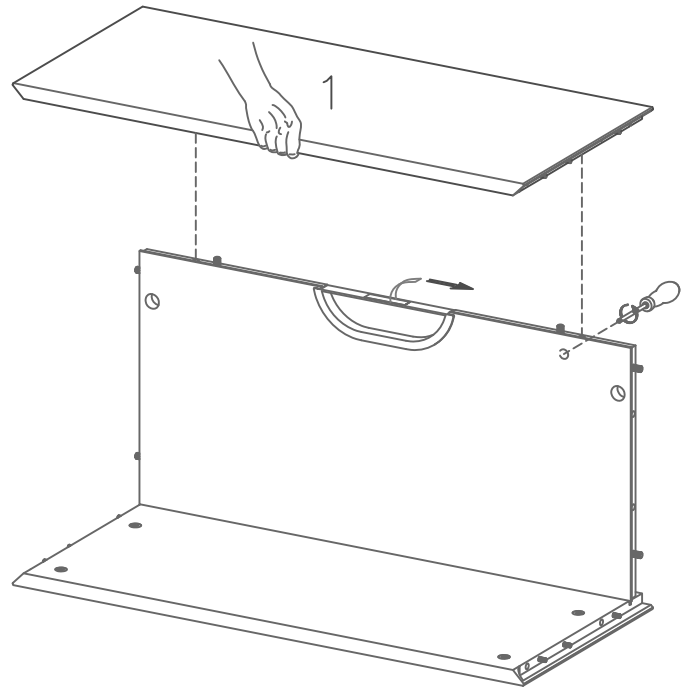

FIG. 6

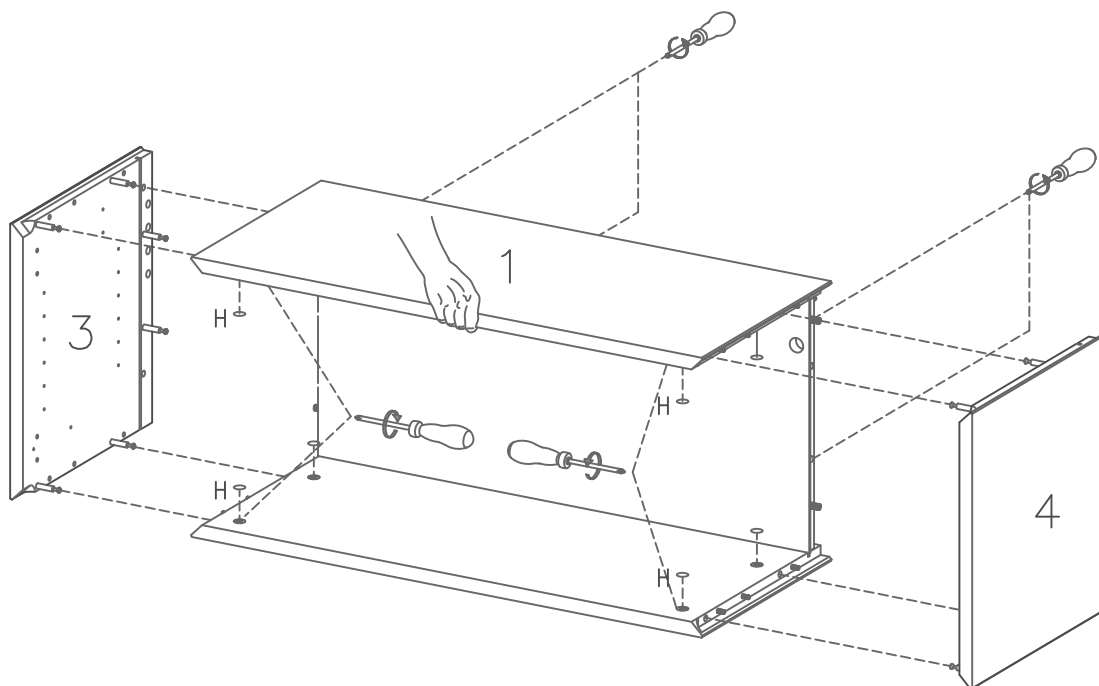

FIG.  
7

# Attention!

DK: Vær opmærksom på vægforholdene, se eksempler.

US: Pay attention to the wall conditions. See example.

D: Sei auf die Wandverhältnisse aufmerksam. Siehe Beispiel.

E: Por favor tener en cuenta las condiciones de las paredes, ver ejemplo.

F: Faites attention au standard du mur, voir les exemples.

NL: Let op de kwaliteit van de muur, zie voorbeelden.

P: Tome atenção às condições da parede. Veja exemplo.

JP: 壁の状態に注意してください。例を見てください。

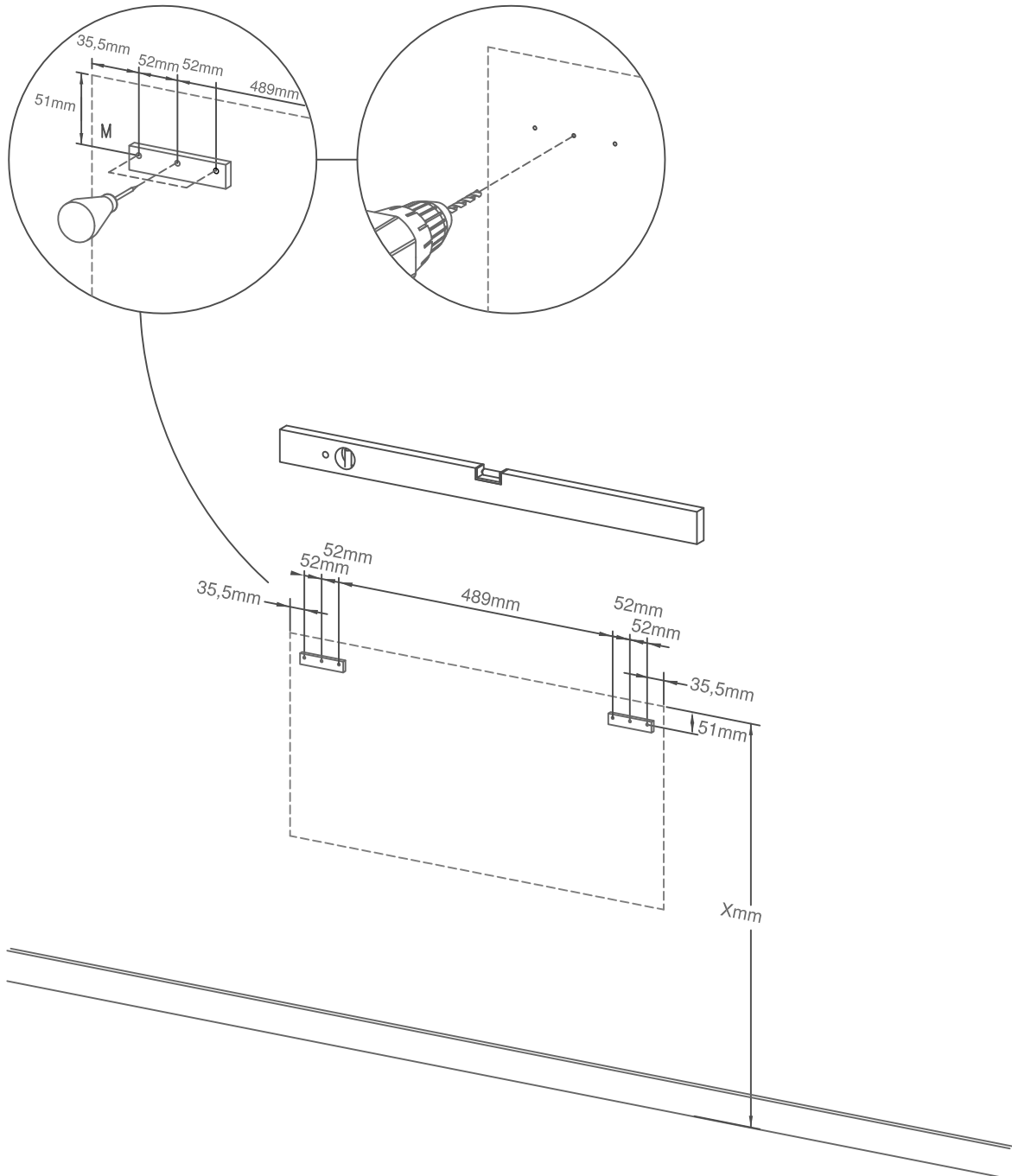
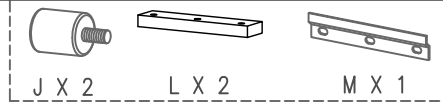





FIG. 8

-  J X 2
-  P X 2
-  Q X 4  
4,0x15mm

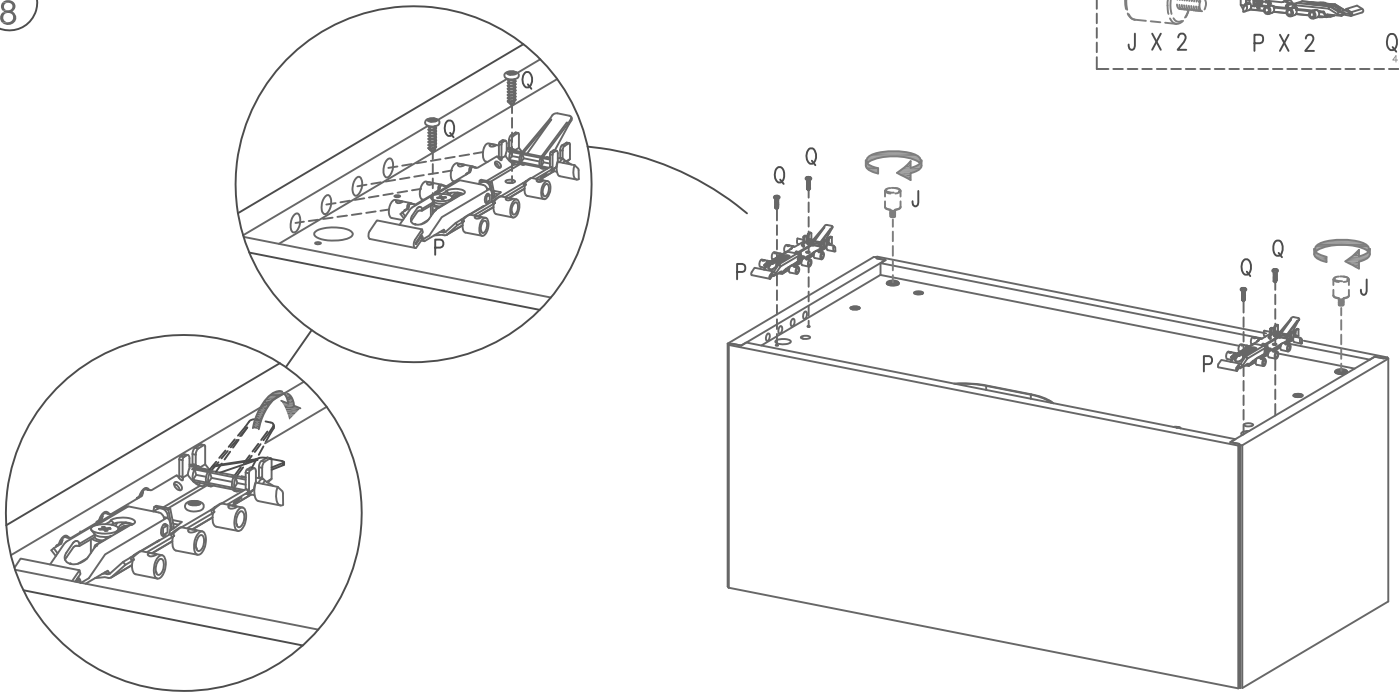

FIG. 9

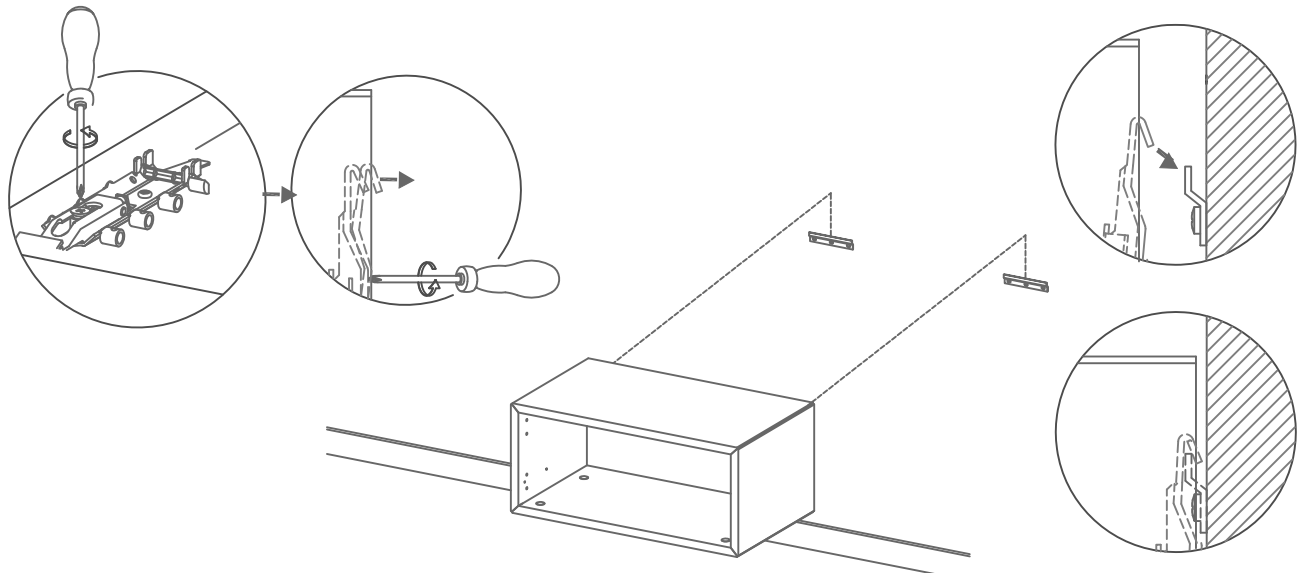
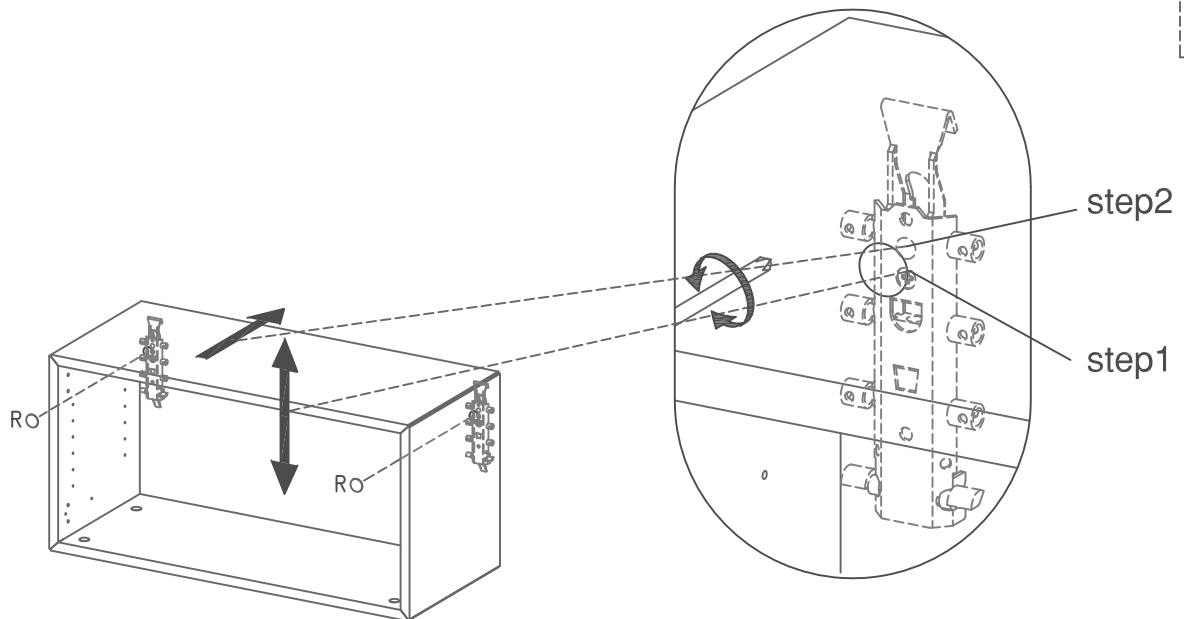
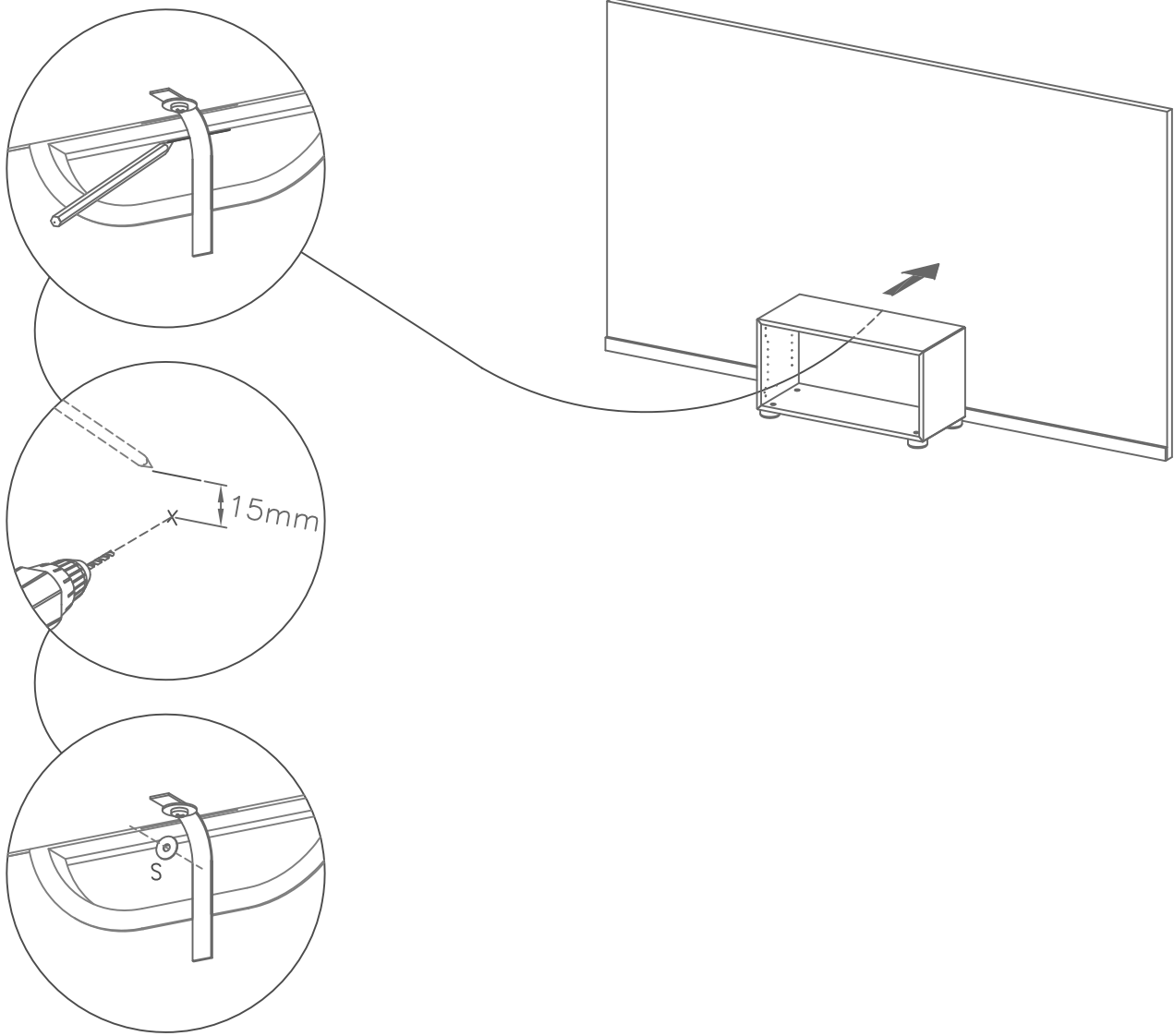

FIG. 10

-  R X 2



Justering - Justierung - Adjusting - Réglage - Bijstelling - Ajuste - Regolazione - Afiinação



- DK Ved reklamation oplyses følgende:
- D Im Reklamationsfall, bitte folgendes erläutern:
- US In case of claims, please state the following:
- F En cas de réclamation, veuillez indiquer:
- NL Bij service volgene mededelen
- E En caso de reclamacion, indicar lo siguiente:
- P No caso de reclamação, por favor indique o seguinte:
- JP お気づきの点等ございましたら、以下の点をお知らせください。

Example!

Korpus - Korpus - Carcase - Carcasse				Beslag - Fittings - Beschläge - Set de Montage		
			A X 8 197200014	B X 12 197200004	C X 4 1979110530	
			C X 2 1970120000	H X 2 1978504022	J X 8 1978204210	